

Communicative spring-return actuator with emergency control function for adjusting dampers in technical building installations

- Air damper size up to approx. 4 m²
- Nominal torque 20 Nm
- Nominal voltage AC/DC 24 V
- Integrated temperature controller
- Communication via LONWORKS® (FTT-10A)
- Conversion of sensor signals

Technical data

Electrical data	Nominal voltage	AC/DC 24 V
	Nominal voltage frequency	50/60 Hz
	Nominal voltage range	AC 19.2...28.8 V / DC 21.6...28.8 V
	Power consumption in operation	8.5 W
	Power consumption in rest position	3.5 W
	Power consumption for wire sizing	11 VA
	Connection supply / control	Cable 1 m, 6 x 0.75 mm ²
Data bus communication	Certified	According to LONMARK® 3.3
	Processor	Neuron 3150
	Transceiver	FTT-10A
	Functional Profile as per LONMARK®	Damper Actuator Object #8110 Open Loop Sensor Object #1 Thermostat Object #8060
	LNS plug-in for actuator / sensor / controller	Can be run with any LNS-based integration tool (Min. for LNS 3.x)
	Service button and status LED	According to LONMARK® guidelines
	Conductors, cables	Signal cable lengths, cable specifications and topology of the LONWORKS® network in accordance with the ECHELON® guidelines
Functional data	Torque motor	Min. 20 Nm
	Torque spring return	Min. 20 Nm
	Position accuracy	±5%
	Direction of motion motor	Selectable with switch L / R
	Direction of motion emergency control function	Selectable by mounting L / R
	Manual override	By means of hand crank and locking switch
	Angle of rotation	Max. 95°
	Angle of rotation note	adjustable starting at 33% in 2.5% steps (with mechanical end stop)
	Running time motor	150 s / 90°
	Motor running time variable	70...220 s
	Running time emergency control position	<20 s / 90°
	Running time emergency setting position note	<20 s @ -20...50°C / <60 s @ -30°C
	Adaption setting range	manual
	Adaption setting range variable	No action Adaption when switched on Adaption after pushing the gear disengagement button
	Override control, controllable via nviManOvrD	MAX (maximum position) = 100% MIN (minimum position) = 0% ZS (intermediate position) = 50%
	Sound power level motor	40 dB(A)
	Spindle driver	Universal spindle clamp 10...25.4 mm
Position indication	Mechanical	
Service life	Min. 60,000 emergency positions	
Safety	Protection class IEC/EN	III Safety extra-low voltage
	Protection class UL	UL Class 2 Supply
	Degree of protection IEC/EN	IP54

Technical data

Safety	Degree of protection NEMA/UL	NEMA 2, UL Enclosure Type 2
	EMC	CE according to 2014/30/EU
	Certification IEC/EN	IEC/EN 60730-1 and IEC/EN 60730-2-14
	Certification UL	cULus according to UL 60730-1A, UL 60730-2-14 and CAN/CSA E60730-1:02
	Mode of operation	Type 1.AA
	Rated impulse voltage supply / control	0.8 kV
	Control pollution degree	3
	Ambient temperature	-30...50 °C
	Non-operating temperature	-40...80 °C
	Ambient humidity	95% r.h., non-condensing
Maintenance	Maintenance-free	
Weight	Weight	2.4 kg

Safety notes



- The device must not be used outside the specified field of application, especially not in aircraft or in any other airborne means of transport.
- Outdoor application: only possible in case that no (sea)water, snow, ice, insolation or aggressive gases interfere directly with the actuator and that is ensured that the ambient conditions remain at any time within the thresholds according to the data sheet.
- Only authorised specialists may carry out installation. All applicable legal or institutional installation regulations must be complied during installation.
- The device may only be opened at the manufacturer's site. It does not contain any parts that can be replaced or repaired by the user.
- The device contains electrical and electronic components and must not be disposed of as household refuse. All locally valid regulations and requirements must be observed.
- Cables must not be removed from the device.

Product features

Mode of operation	The actuator is equipped with an integrated interface for LONWORKS®. The actuator can be directly connected to the LON network and controlled via the transceiver FTT-10A
Converter for sensors	Connection option for a sensor (passive or active sensor or switching contact). In this way, the analogue sensor signal can be easily digitised and passed along to LONWORKS®.
Integrated temperature controller	The device has an integrated temperature controller (Thermostat Object LONMARK® #8060). Other control variants upon request. The temperature controller can be set using the LNS Plug-In from Belimo.
Parameterisable actuators	The factory settings cover the most common applications. Single parameters can be modified with the Belimo Service Tools MFT-P or ZTH EU.
Simple direct mounting	Simple direct mounting on the damper spindle with an universal spindle clamp, supplied with an anti-rotation device to prevent the actuator from rotating.
Manual override	By using the hand crank the damper can be actuated manually and engaged with the locking switch at any position. Unlocking is carried out manually or automatically by applying the operating voltage.
High functional reliability	The actuator is overload protected, requires no limit switches and automatically stops when the end stop is reached.
Adjustable angle of rotation	Adjustable angle of rotation with mechanical end stops.
Home position	The first time the supply voltage is switched on, i.e. at the time of commissioning, the actuator carries out a synchronisation. The synchronisation is in the home position (0%). The actuator then moves into the position defined by the positioning signal.

Product features

Adaption and synchronisation An adaption can be triggered manually by pressing the “Adaption” button or with the PC-Tool. Both mechanical end stops are detected during the adaption (entire setting range). Automatic synchronisation after actuating the hand crank is programmed. The synchronisation is in the home position (0%). The actuator then moves into the position defined by the positioning signal. A range of settings can be adapted using the PC-Tool (see MFT-P documentation)

Accessories

	Description	Type
Electrical accessories	Auxiliary switch, 2 x SPDT	S2A-F
	Feedback potentiometer, 200 Ohm, incl. installation accessories	P200A-F
	Feedback potentiometer 1 kOhm, incl. installation accessories	P1000A-F
	Connecting cable 5 m, A+B: RJ12 6/6, To ZTH/ZIP-USB-MP	ZK1-GEN
	Connection cable 5 m, A: RJ11 6/4, B: Free wire end, To ZTH/ZIP-USB-MP	ZK2-GEN
Mechanical accessories	Description	Type
	Shaft extension 250 mm, for damper spindles Ø 8...25 mm	AV8-25
	End stop indicator for NF..A / SF..A	IND-AFB
	Spindle clamp set for NF..A/SF..A (1", 3/4", 1/2")	K7-2
	Straight ball joint with M8, suitable for damper crank arms KH8	KG10A
	Angled ball joint with M8, suitable for damper crank arms KH8	KG8
	Damper crank arm, for damper spindles	KH8
	Damper crank arm for NF..A / SF..A, for 3/4" spindles	KH-AFB
	Form fit insert 10x10 mm, for spring return actuators NG	ZF10-NSA-F
	Form fit insert 12x12 mm, for spring return actuators NG	ZF12-NSA-F
	Form fit insert 16x16 mm, for spring return actuators NG	ZF16-NSA-F
	Damper crank arm, for spring return actuators NG	ZG-AFB
Base plate extensions for NF..A/SF..A	Z-SF	
Service Tools	Description	Type
	Service Tool, for MF/MP/Modbus/LonWorks actuators and VAV-Controller	ZTH EU
	Belimo PC-Tool, software for adjustments and diagnostics	MFT-P
	Adapter to Service Tool ZTH	MFT-C

Electrical installation

Notes • Connection via safety isolating transformer.

Wiring diagrams

Connection without sensor

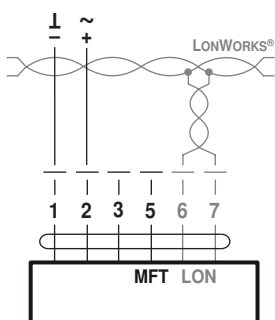

Connection with passive sensor, e.g. Pt1000, Ni1000, NTC

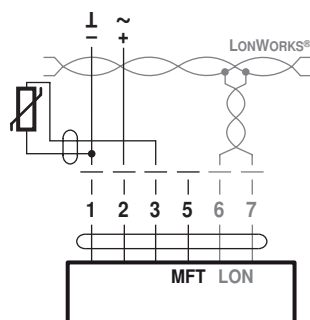

Ni1000	-28...+98°C	850...1600 Ω ²⁾
PT1000	-35...+155°C	850...1600 Ω ²⁾
NTC	-10...+160°C ¹⁾	200 Ω...60 kΩ ²⁾

Sensor scaling:
The sensors can be scaled with the sensor plug-in (sensor table).
1) Depending on type
2) Resolution 1 Ohm

Electrical installation

Connection with switching contact, e.g. Δp monitor

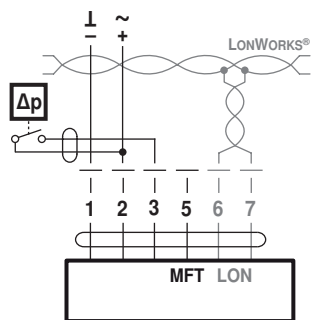

Switching contact requirements:
The switching contact must be able to switch a current of 16 mA at 24 V accurately.

Connection with active sensor, e.g. 0...10 V @ 0...50°C

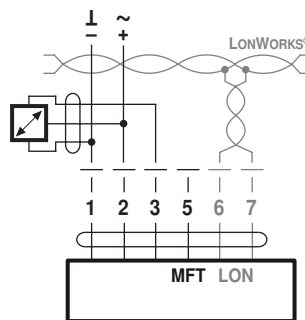

Possible voltage range:
0...32V (Resolution 30 mV)
Sensor scaling:
The sensors can be scaled with the sensor plug-in (sensor table)

Functional Profile as per LONMARK®

The LON-capable actuator is certified by LONMARK®. The following actuator functions are made available via the LONWORKS® network as standardised network variables in accordance with LONMARK®: the Node Object #0, the Damper Actuator Object #8110, the Open Loop Sensor Object #1 and the Thermostat Object #8060.

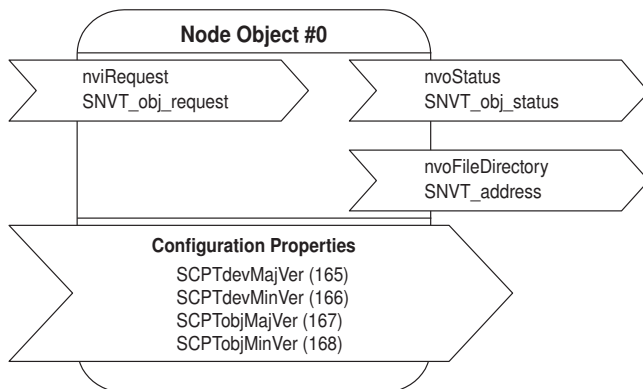

Node Object #0

The node object contains the object status and object request functions.

nviRequest: SNVT_obj_request

Input variable for requesting the status of a particular object in the node.

nvoStatus: SNVT_obj_status

Output variable that outputs the current status of a particular object in the node.

nvoFileDirectory: SNVT_address

Output variable that shows information in the address range of the Neuron chip.

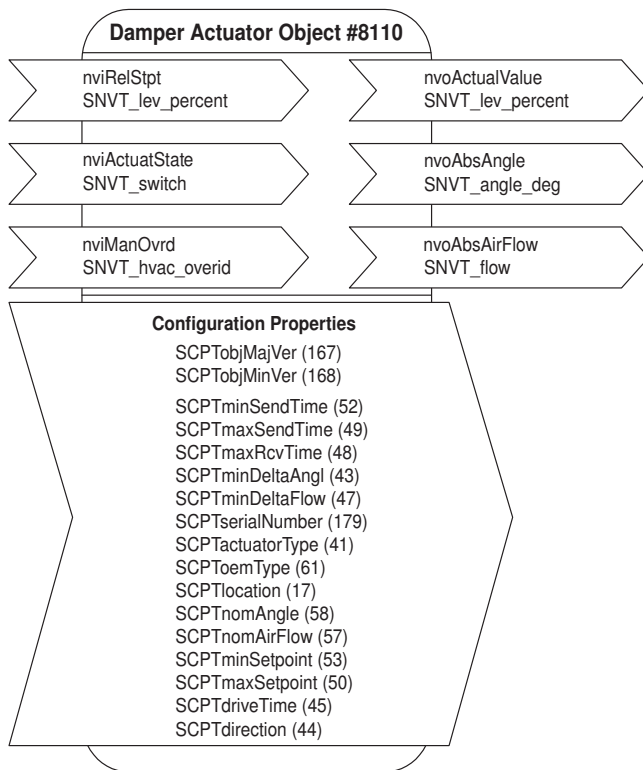

Damper Actuator Object #8110

The actuator object is used to display the functions of the actuator on the page of the LONWORKS® network.

nviRelStpt: SNVT_lev_percent

Via this input variable, the setpoint in % for the actuator is specified (0...100% = Min...Max). This variable is normally linked to the output variable of an HVAC controller.

nviActuateState: SNVT_switch

A preset position is assigned to the actuator via this input variable. Note on priority: The variable which was most recently active, either nviActuatorState or nviRelStpt, has priority.

nviManOvrd: SNVT_hvac_overid

see table «Override control with SNVT nviManOvrd»

nvoActualValue: SNVT_lev_percent

This output variable shows the current actual position of the actuator and can be used for control circuit feedback or for displaying positions.

nvoAbsAngle: SNVT_angle_deg

This output variable shows the current angle of rotation / stroke of the actuator and can be used to display the position or for service purposes.

nvoAbsAirFlow: SNVT_flow

This output variable is inactive with this actuator and shows a constant value of 65535 (this variable is only active in conjunction with LON-capable VAV controllers).

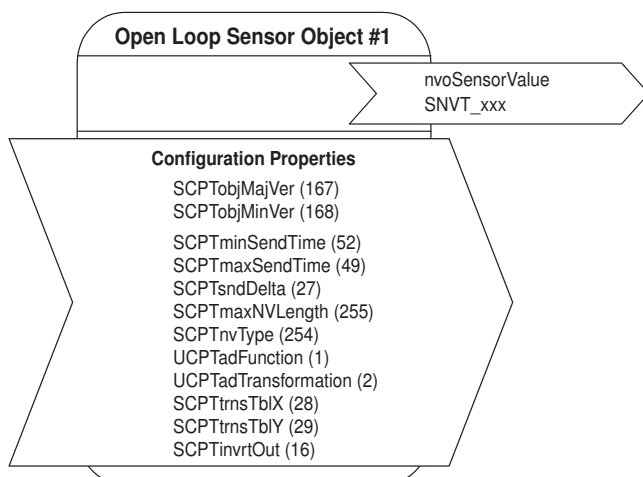

Open Loop Sensor Object #1

One sensor can be connected to the actuator.

A passive resistance sensor (e.g. Ni1000), an active sensor (output 0...32 V) or a switch (On/Off) can be connected. In the case of the open loop sensor object, the measured sensor values are transferred to the LONWORKS® network.

nvoSensorValue: SNVT_xxx

This output variable shows the current sensor value. Depending on the connected sensor, the output variable can be configured via the sensor plug-in and specifically adapted to the system.

The SNVT .. can be configured as:

SNVT_temp_p	SNVT_lev_percent	SNVT_lux
SNVT_temp	SNVT_abs_humid	SNVT_press_p
SNVT_switch	SNVT_enthalpy	SNVT_smo_obscur
SNVT_flow	SNVT_ppm	SNVT_power
SNVT_flow_p	SNVT_rpm	SNVT_elec_kwh

Functional Profile as per LONMARK®

Individual room control solutions can be implemented with the thermostat object LONMARK® #8060. An LNS plug-in is available for configuring the controller parameters.

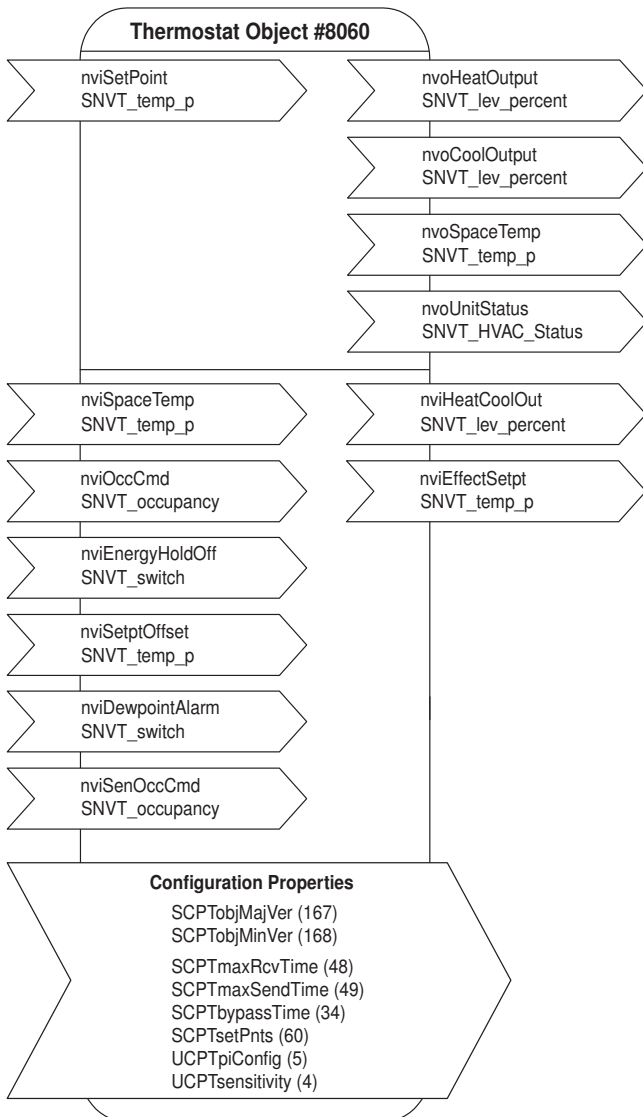

Thermostat Object #8060

nviSetPoint: SNVT_temp_p

Setpoint specification for the controller from the higher-level system or the room control unit. If this variable is not linked, then the local setpoints of the controller object apply (can be adjusted via plug-in). The setpoint specification from the higher-level system influences the setting on the controller as follows:

Example: Comfort setpoint for heating = 21 °C and Comfort setpoint for cooling = 23 °C. The median point between heating and cooling is thus 22 °C. Now, if the external setpoint (nviSetPoint) is 23 °C, then the heating setpoint will shift to 22 °C and the cooling set point to 24 °C. The setpoints for Pre-Comfort heating and cooling will also be shifted accordingly.

nviSpaceTemp: SNVT_temp_p

Room temperature from external room sensor. It is imperative that this variable be linked; typically, it is linked with the variable of the sensor object.

nviOccCmd: SNVT_occupancy

Occupancy specification from the command centre (for the function, see the table entitled «Functions Inputs Occupancy» next page).

nviEnergyHoldOff: SNVT_switch

In the case of active EnergyHoldOff, the controller will be set to the Building Protection setpoints.

nviSetptOffset: SNVT_temp_p

Shifting of the room control unit. If the nviSetPoint is linked, then this input has an influence on the variable value of nviSetPoint, i.e. it corrects it. Otherwise, the Comfort and Pre-Comfort setpoints for heating and cooling will be adjusted directly by the amount of the shift (compare example with nviSetPoint).

nviDewpointAlarm: SNVT_switch

In the case of active DewpointAlarm, the controller will be set to the Building Protection setpoints. The cooling sequence is deactivated.

nviSenOccCmd: SNVT_occupancy

Occupancy specification from the local occupancy switch (for the function, see the table entitled «Functions Inputs Occupancy» next page).

nvoHeatOutput: SNVT_lev_percent

Control signal for heating.

nvoCoolOutput: SNVT_lev_percent

Control signal for cooling.

nvoSpaceTemp: SNVT_temp_p

Displays the room temperature of the nviSpaceTemp. If nviSpaceTemp is not linked, then the variable will display the value 0x7FFF.

nvoUnitStatus: SNVT_HVAC_Status

Displays the operating mode of the controller (in accordance with Functional Profile #8060).

nvoHeatCoolOut: SNVT_lev_percent

Depicts the heating and cooling sequence for controlling the 6-way characterised control valves (see illustration, next page).

This outlet runs parallel to the nvoCoolOutput or the nvoHeatOutput, respectively.

Cooling = 33...0%

Valve closed 33...66%

Heating = 66...100%

nvoEffectSetpt: SNVT_temp_p

Shows the actual setpoint of the controller.

Note

A restart is necessary after accessing network variables for the purpose of rewriting them or after deleting links in order to initialise the variables.

Functional Profile as per LONMARK®

Functions Inputs Occupancy

Note

The function nviOccCmd has a higher priority than the function nviSenOccCmd.

Occupancy specification from nviOccCmd command centre	Occupancy switch nviSenOccCmd	Room operating status	Comfort extension
OC_OCCUPIED	OC_OCCUPIED	Comfort	
	OC_UNOCCUPIED	Comfort	
	OC_NUL (default)	Comfort	
OC_STANDBY	OC_OCCUPIED	Bypass	Occupied time is extended by the amount of the bypass time (comfort time) (can be adjusted in the plug-in)
	OC_UNOCCUPIED	Pre-Comfort	
	OC_NUL (default)	Pre-Comfort	
OC_UNOCCUPIED	OC_OCCUPIED	Building Protection	
	OC_UNOCCUPIED	Building Protection	
	OC_NUL (default)	Building Protection	
OC_NUL (default)	OC_OCCUPIED	Comfort	
	OC_UNOCCUPIED	Pre-Comfort	
	OC_NUL (default)	Comfort	

Funktion nvoHeatCoolOut

Typical application

Heating / cooling with Belimo 6-way characterised control valve.

Note chilled ceiling application

In the case of active DewPointAlarm (nviDewPointAlarm), the controller will be set to the Building Protection setpoints. The cooling sequence is deactivated.

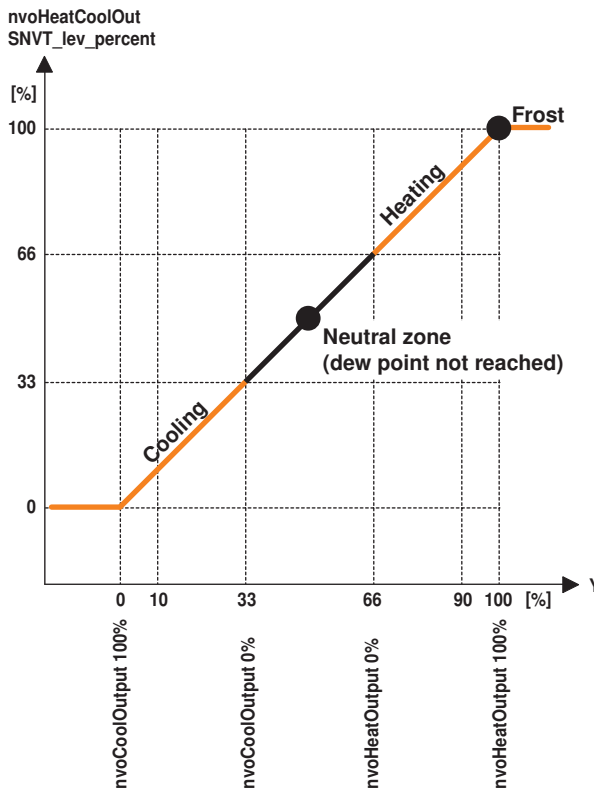

Override control with the SNVT nviManOvr

Note

The basic setting is «HVO_OFF». This value is loaded when the power supply is switched on.

Note

More detailed information on the functional profiles can be found on the website of LONMARK®. (www.lonmark.org).

State	Value	Actuator
HVO_OFF	–	Override control inactive
HVO_POSITION	percent	Position in % (MIN...MAX)
HVO_FLOW_VALUE	flow	–
HVO_FLOW_PERCENT	percent	–
HVO_OPEN	–	Full open
HVO_CLOSE	–	Full closed
HVO_MINIMUM	–	Minimum position
HVO_MAXIMUM	–	Maximum position

Operating controls and indicators

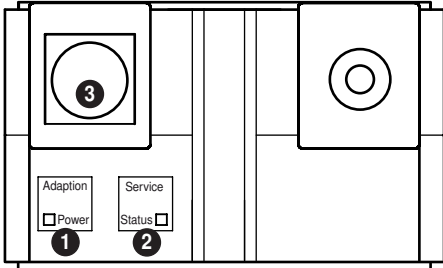

1 Membrane button and LED display green

Off: No power supply or malfunction
 On: In operation
 Press button: Triggers angle of rotation adaptation, followed by standard mode

2 Service membrane key for commissioning at LONWORKS® and LED display yellow for LON status

Off: The actuator is linked to the LONWORKS® and ready for operation
 On: No application software is loaded in the actuator
 Flashing, interval 2 s: The actuator is ready for operation, but not linked to the LONWORKS® (unconfigured)
 Other flashing codes: There is a malfunction in the actuator
 Press button: Service Pin Message is sent to the LONWORKS®

3 Service plug

For connecting parameterisation and service tools

Operating elements

The manual override, locking switch and direction of rotation switch elements are available on both sides

Service

Service Tools connection The actuator can be parameterised by ZTH EU via the service socket. For an extended parameterisation the PC tool can be connected.

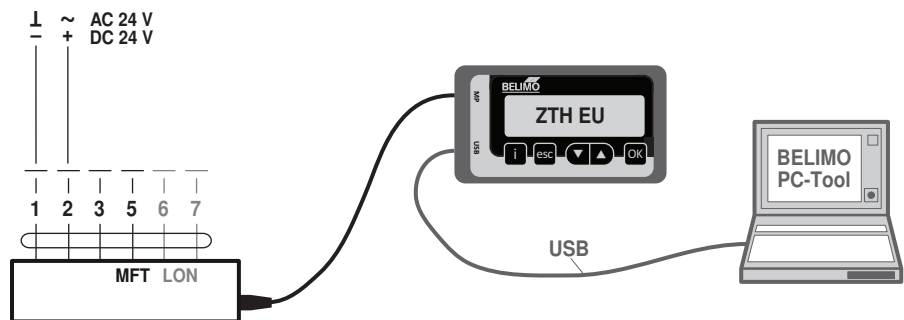

Dimensions [mm]

Spindle length

	Min. 85
	Min. 15

Clamping range

	10...22	10	14...25.4
	19...25.4	12...18	

Dimensional drawings

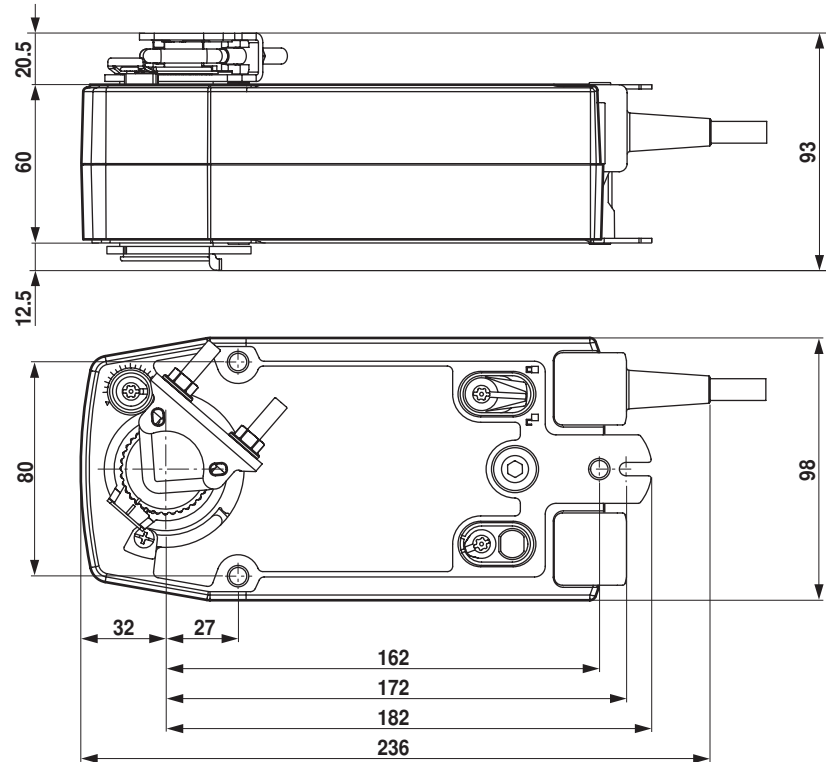

Further documentation

- Applications with integrated temp. controller
- LON actuators with CO₂ control
- Actuator Plug-in description
- Sensor Plug-in description
- Controller Plug-in description
- Tool connections
- LonWorks® Glossary