

Parameterisable spring-return actuator with emergency control function for adjusting dampers in technical building installations

- Air damper size up to approx. 6 m²
- Nominal torque 30 Nm
- Nominal voltage AC/DC 24 V
- Control Modulating DC (0)2...10 V Variable
- Position feedback DC 2...10 V Variable

Technical data

Electrical data	Nominal voltage	AC/DC 24 V
	Nominal voltage frequency	50/60 Hz
	Nominal voltage range	AC 19.2...28.8 V / DC 21.6...28.8 V
	Power consumption in operation	9.5 W
	Power consumption in rest position	4.5 W
	Power consumption for wire sizing	16 VA
	Connection supply / control	Cable 1 m, 4 x 0.75 mm ²
	Parallel operation	Yes (note the performance data)
Functional data	Torque motor	Min. 30 Nm
	Torque spring return	Min. 30 Nm
	Positioning signal Y	DC 0...10 V
	Positioning signal Y note	Input impedance 100 kΩ
	Control signal Y variable	Open-close 3-point (AC only) Modulating (DC 0...32 V)
	Operating range Y	DC 2...10 V
	Operating range Y variable	Start point DC 0.5...30 V End point DC 2.5...32 V
	Position feedback U	DC 2...10 V
	Position feedback U note	Max. 0.5 mA
	Position feedback U variable	Start point DC 0.5...8 V End point DC 2.5...10 V
	Position accuracy	±5%
	Direction of motion motor	Selectable with switch L / R
	Direction of motion variable	Electronically reversible
	Direction of motion emergency control function	Selectable by mounting L / R
	Manual override	By means of hand crank and locking switch
	Angle of rotation	Max. 95°
	Angle of rotation note	adjustable starting at 33% in 5% steps (with mechanical end stop)
	Running time motor	150 s / 90°
	Motor running time variable	60...150 s
	Running time emergency control position	<20 s / 90°
	Running time emergency setting position note	<20 s @ -20...50°C / <60 s @ -30°C
	Adaption setting range	manual (automatic on first power-up)
	Adaption setting range variable	No action Adaption when switched on Adaption after pushing the gear disengagement button
	Override control	MAX (maximum position) = 100% MIN (minimum position) = 0% ZS (intermediate position, AC only) = 50%
	Override control variable	MAX = (MIN + 32%)...100% MIN = 0%...(MAX - 32%) ZS = MIN...MAX
	Sound power level motor	45 dB(A)
	Sound power level emergency control position	71 dB(A)

Technical data

Functional data	Spindle driver	Universal spindle clamp 12...26.7 mm
	Position indication	Mechanical
	Service life	Min. 60,000 emergency positions
Safety	Protection class IEC/EN	III Safety extra-low voltage
	Degree of protection IEC/EN	IP54
	EMC	CE according to 2004/108/EC
	Certification IEC/EN	IEC/EN 60730-1 and IEC/EN 60730-2-14
	Mode of operation	Type 1.AA
	Rated impulse voltage supply / control	0.8 kV
	Control pollution degree	3
	Ambient temperature	-30...50 °C
	Non-operating temperature	-40...80 °C
	Ambient humidity	95% r.h., non-condensing
Maintenance	Maintenance-free	
Weight	Weight	5.2 kg

Safety notes



- The device must not be used outside the specified field of application, especially not in aircraft or in any other airborne means of transport.
- Outdoor application: only possible in case that no (sea)water, snow, ice, insolation or aggressive gases interfere directly with the actuator and that is ensured that the ambient conditions remain at any time within the thresholds according to the data sheet.
- Only authorised specialists may carry out installation. All applicable legal or institutional installation regulations must be complied during installation.
- The device may only be opened at the manufacturer's site. It does not contain any parts that can be replaced or repaired by the user.
- Cables must not be removed from the device.
- To calculate the torque required, the specifications supplied by the damper manufacturers concerning the cross-section, the design, the installation site and the ventilation conditions must be observed.
- The device contains electrical and electronic components and must not be disposed of as household refuse. All locally valid regulations and requirements must be observed.

Product features

Mode of operation	The actuator moves the damper to the operating position at the same time as tensioning the return spring. The damper is turned back to the emergency position by spring force when the supply voltage is interrupted. The actuator is connected with a standard modulating signal of DC 0...10V and drives to the position defined by the positioning signal. Measuring voltage U serves for the electrical display of the damper position 0...100% and as slave control signal for other actuators.
Parameterisable actuators	The factory settings cover the most common applications. Single parameters can be modified with the Belimo Service Tools MFT-P or ZTH EU.
Simple direct mounting	Simple direct mounting on the damper spindle with an universal spindle clamp, supplied with an anti-rotation device to prevent the actuator from rotating.
Spindle stabiliser	The spindle clamp of the spring-return actuator is factory-equipped with an axis stabiliser for the stabilisation of the combination of damper, damper spindle and actuator. This is comprised of two plastic support rings and must be left in place, partially or completely removed, depending on the installation situation and the axis diameter.
Manual override	By using the hand crank the damper can be actuated manually and engaged with the locking switch at any position. Unlocking is carried out manually or automatically by applying the operating voltage.
High functional reliability	The actuator is overload protected, requires no limit switches and automatically stops when the end stop is reached.
Adjustable angle of rotation	Adjustable angle of rotation with mechanical end stops.

Product features

Home position	The first time the supply voltage is switched on, i.e. at the time of commissioning, the actuator carries out an adaption, which is when the operating range and position feedback adjust themselves to the mechanical setting range. The actuator then moves into the position defined by the positioning signal.
Adaption and synchronisation	An adaption can be triggered manually by pressing the “Adaption” button or with the PC-Tool. Both mechanical end stops are detected during the adaption (entire setting range). Automatic synchronisation after actuating the hand crank is programmed. The synchronisation is in the home position (0%). The actuator then moves into the position defined by the positioning signal. A range of settings can be adapted using the PC-Tool (see MFT-P documentation)

Accessories

	Description	Type
Electrical accessories	Signal converter voltage/current, supply AC/DC 24V	Z-UIC
	Digital position indicator for front-panel mounting, 0...99%, front mass 72 x 72 mm	ZAD24
	Range controller for wall mounting, adjustable electron. Min./max. angle of rotation limitation	SBG24
	Positioner for wall mounting, range 0...100%	SGA24
	Positioner in a conduit box, range 0...100%	SGE24
	Positioner for front-panel mounting, range 0...100%	SGF24
	Positioner for wall mounting, range 0...100%	CRP24-B1
	Connecting cable 5 m, A+B: RJ12 6/6, To ZTH/ZIP-USB-MP	ZK1-GEN
	Connection cable 5 m, A: RJ11 6/4, B: Free wire end, To ZTH/ZIP-USB-MP	ZK2-GEN
Mechanical accessories	Description	Type
	End stop indicator for EF..A	IND-EFB
	Spindle clamp set for EF..A (1", 3/4"), for damper spindles Ø 12...26.7	K9-2
	Damper crank arm, for damper spindles	KH10
	Actuator arm for EF..A	KH-EFB
Mounting kit for linkage operation	ZG-EFB	
Service Tools	Description	Type
	Service Tool, for MF/MP/Modbus/LonWorks actuators and VAV-Controller	ZTH EU
	Belimo PC-Tool, software for adjustments and diagnostics	MFT-P
Adapter to Service-Tool ZTH	MFT-C	

Electrical installation



Notes

- Connection via safety isolating transformer.
- Parallel connection of other actuators possible. Observe the performance data.

Wiring diagrams

AC/DC 24 V, modulating

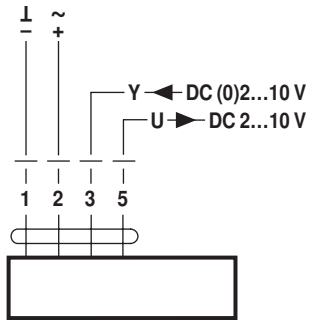

Cable colours:
 1 = black
 2 = red
 3 = white
 5 = orange

Parallel operation

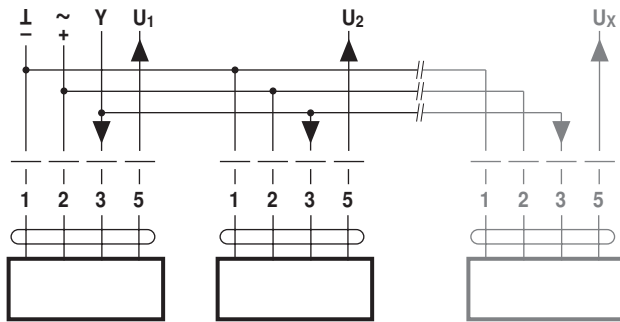

Notes

- A maximum of eight actuators can be connected in parallel.
- Parallel operation is permitted only on non-connected axes.
- Do not fail to observe performance data with parallel operation.

Piggyback operation wiring diagram

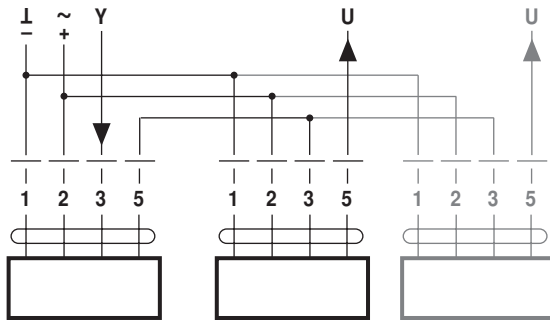

Notes

- Two or a maximum of three actuators can be connected in Master-Slave operation.
- Master-Slave operation is permitted only on one fixed axis or on two or three mechanically coupled axes.
- The programming of the Master actuator is adopted by the Slave actuators.

Functions

Functions with basic values (conventional mode)

Override control with AC 24 V with relay contacts

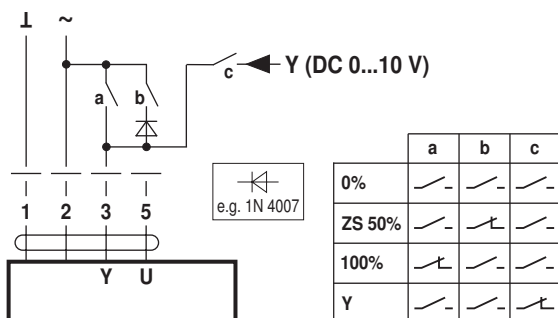

Override control with AC 24 V with rotary switch

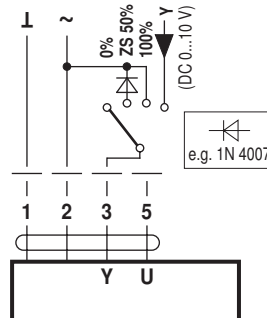

Functions

Remote control 0...100% with positioner SG.. Minimum limit with positioner SG..
positioner SG..

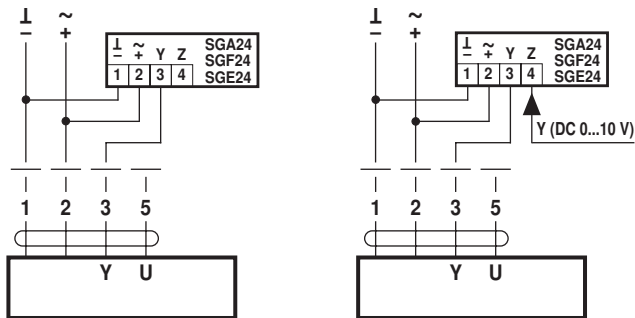

Follow-up control (position-dependent)

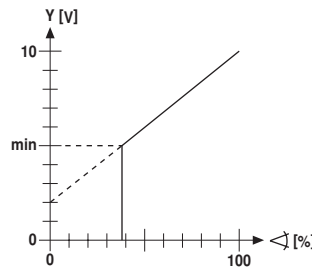

Position indication

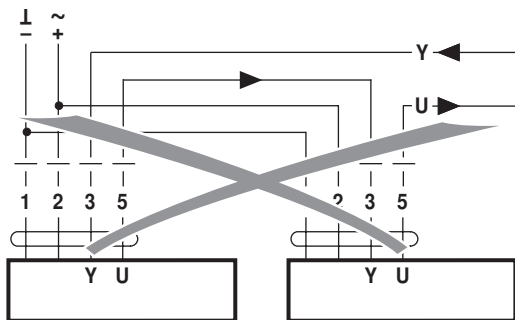

Control with 4...20 mA via external resistor

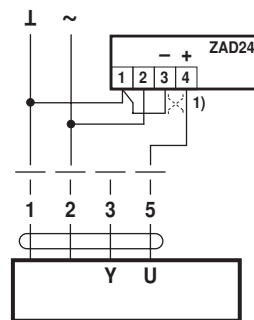

Functional check

(1) Adapting the direction of rotation

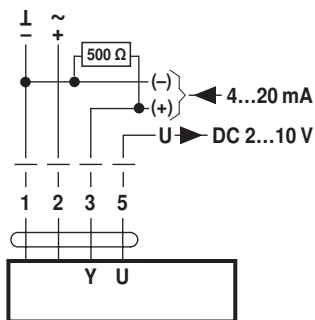

Caution:
The operating range must be set to DC 2...10 V.
The 500 Ω resistor converts the 4...20 mA current signal to a voltage signal DC 2...10 V

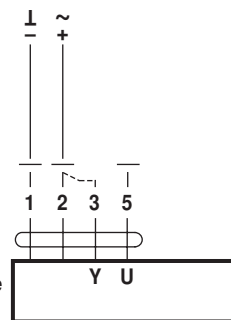

- Procedure**
1. Connect 24V to connections 1 and 2
 2. Disconnect connection 3:
 - with direction of rotation 0: Actuator rotates to the left
 - with direction of rotation 1: Actuator rotates to the right
 3. Short-circuit connections 2 and 3:
 - Actuator runs in opposite direction

Functions for actuators with specific parameters (Parametrisation with PC-Tool necessary)

Override control and limiting with AC 24 V with relay contacts

Override control and limiting with AC 24 V with rotary switch

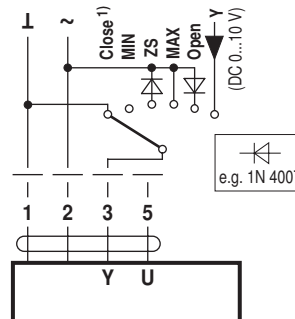
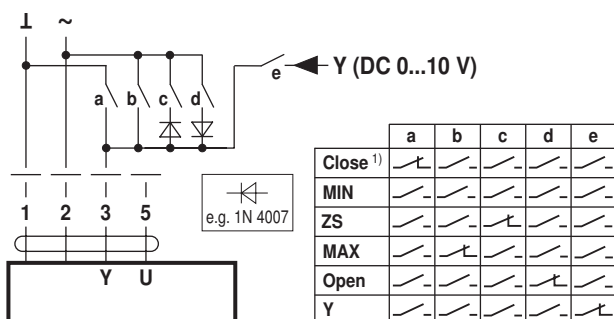

1) **Caution:** This function is only guaranteed if the start point of the operating range is defined as min. 0.5 V.

Functions

Control open-close

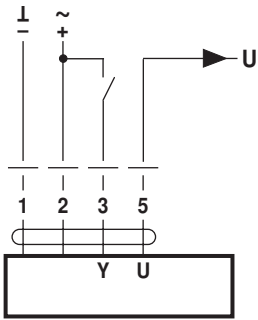

Control 3-point

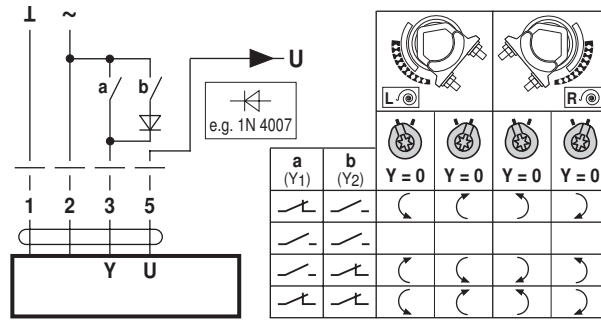

Operating controls and indicators

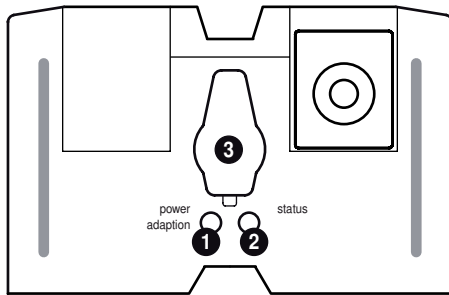

- 1 Push-button and LED display green**
 Off: No power supply or malfunction
 On: In operation
 Press button: Triggers angle of rotation adaptation, followed by standard mode
- 2 Push-button and LED display yellow**
 Off: Standard mode
 On: Adaptation or synchronising process active
 Press button: No function

- 3 Service plug**
 For connecting the parameterisation and service tools

Check power supply connection

- 1** Off and **2** On: Possible wiring error in power supply

Installation notes

	Notes	<ul style="list-style-type: none"> • The spindle stabiliser must nevertheless be used with installation of the anti-rotation device on the opposite side of the spindle clamp and a spindle diameter <20 mm.
--	--------------	--

Spindle stabiliser long spindle mounting In the case of long spindle installation the use of the spindle stabiliser at a spindle diameter of

- 12 to 20 mm is necessary
- 21 to 26.7 mm is not necessary and can be removed

Spindle stabiliser short spindle mounting In the case of short spindle installation, the necessity of the spindle stabiliser is dispensed with. It can be removed or – if the spindle length permits this – left in the clamp.

Service

	Notes	<ul style="list-style-type: none"> • The actuator can be parameterised by PC-Tool and ZTH EU via the service socket.
--	--------------	---

Service

Servive Tools connection ZTH EU connection

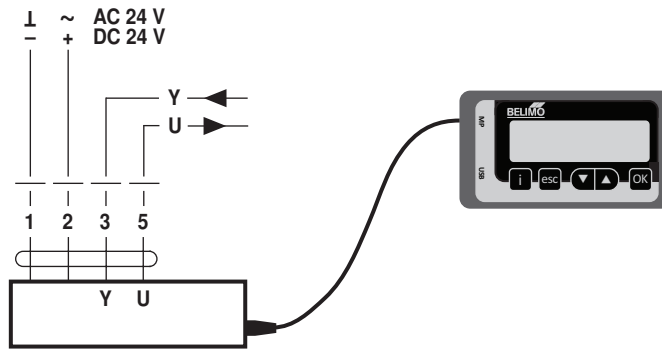

PC-Tool connection

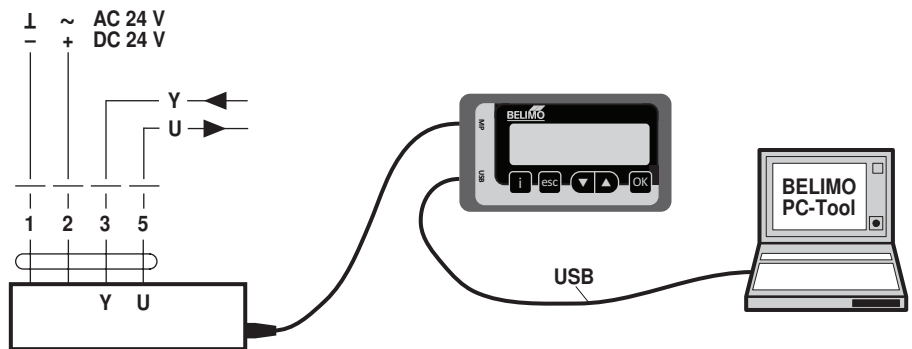

Dimensions [mm]

Spindle length

		Min. 117
		Min. 20

Clamping range

	12...22	12...18
	22...26.7	12...18

Dimensional drawings

